

styling

Canguro

GLOBAL INTERIER

GLOBAL INTERIER, M.Hökl

Masná 34, 602 00 Brno

Tel. +420 548210647, 8

Fax. +420 548210647, 8

www.globalinterier.com

info@globalinterier.com



english

Thanks to a set of kinematic mechanisms equipped with gas-powered pumps the front-side sliding system allows the use of the compartment under the spring for cushions and blankets.

It is realized with highly-resistant cold-rolled steel tubes of top quality and is lacquered with epoxy resins in high temperature oven.

The orthopedic bed base is made up of curved wooden slats.

The version with the iron frame that can be completely disassembled is also available.

A simple and rapid assembly allows the sale of the kit.

español

Cama que, al levantar el somier, deja libre un hueco puesto debajo del el, útil para guardar almohadas y mantas: este movimiento está permitido por una pareja de mecanismos cinemáticos de levantamiento dotados de bombas de gas.

Ha sido realizado con tubos de acero rodados en frío de alta resistencia; está barnizado a polvo en horno en alta temperatura.

El somier es ortopédico, hecho por láminas de haya curvas.

Disponibile también en la versión con armazón en hierro, aunque este completamente desmontable.

Como es posible montarlo muy sencilla y rápidamente, permite que se venda en kit de montaje.

italiano

Letto contenitore che, mediante sollevamento del piano dormita, rende disponibile un vano collocato sotto la rete, utile per riporre cuscini e coperte: tale movimento è consentito da una coppia di cinematismi di sollevamento dotati di pompe a gas. È realizzato con tubi in acciaio formati a freddo di qualità ad alta resistenza; è verniciato a polvere in forno ad alta temperatura.

Il piano dormita è ortopedico, in doghe di legno curve.

Disponibile anche nella versione con telaio in ferro, anch'esso completamente smontabile.

La possibilità di essere montato con estrema facilità e velocità ne consente la vendita in kit.

français

Grâce à un système de soulèvement du plan couchage actionné par un couple cinématique de soulèvement pourvu de pompes à gaz, il est possible d'utiliser un coffre de rangement pour les coussins et les couvertures. Le système est réalisé avec des tubes en acier forgés à froid à haute résistance de bonne qualité. Vernissage à la poudre époxyde noire cuite au four à haute température.

Plan de couchage orthopédique avec lattes courbées en bois.

La version avec le châssis en fer complètement démontable est aussi disponible.

Grâce à son assemblage simple et rapide il est possible de vendre le modèle en kit.

deutsch

Bettsofa mit Kasten; beim Anheben der Liegefläche kommt sich unter dem Metallgitterrost ein Kastenzum Vorschein, wo man Kissen und Decken unterbringen kann.

Diese Bettmechanik wird durch zwei Gaspumpengetriebe betätigt.

Höchst widerstandsfähige Struktur aus kaltgeformten Stahlröhren mit Pulver bei hoher Temperatur ofenlackiert.

Die orthopädische Liegefläche ist mit gebogenen Holzlatten ausgestattet.

Erhältlich auch in der Ausführung mit Eisenrahmen, die ebenso völlig zerlegbar ist.

Dank der einfachen und schnellen Montage kann dieses Bettsofa gut als Kit verkauft werden.



styling

Canguro

con Cassone

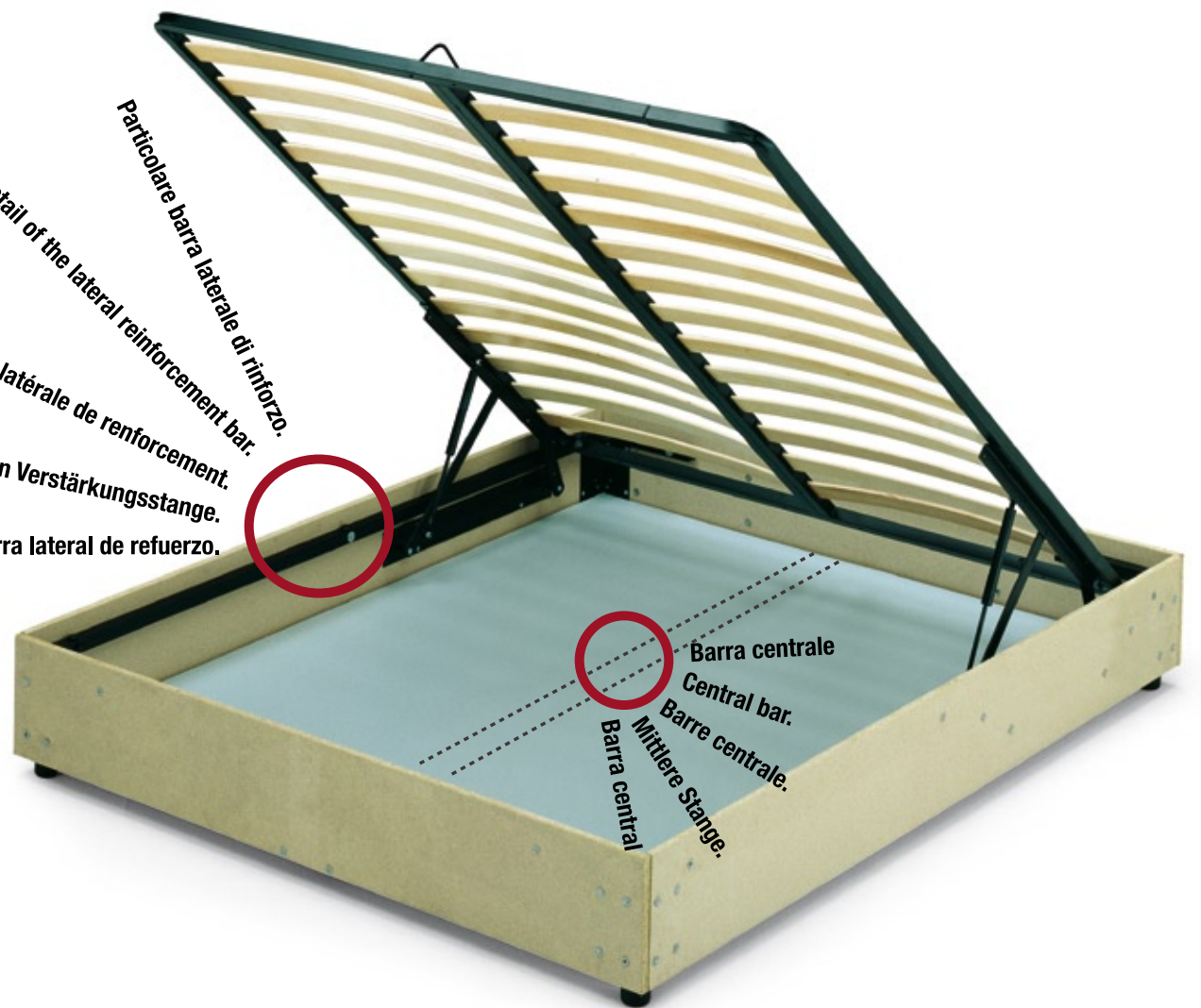

Particolare barra laterale di rinforzo.

Detail of the lateral reinforcement bar.

Détail de la barre latérale de renforcement.

Detail der seitlichen Verstärkungsstange.

Detalle de la barra lateral de refuerzo.

Barra centrale
Central bar.
Barre centrale.
Mittlere Stange.
Barra central



styling

Canguro

con Telaio



Versione con telaio in ferro

Version with the iron frame

Version avec le châssis en fer

Ausführung mit Eisenrahmen

Versión con armazón en hierro



styling

Canguro

Kit di montaggio

Assembly kit · Kit d'assemblage · Montagekit · Kit de montage

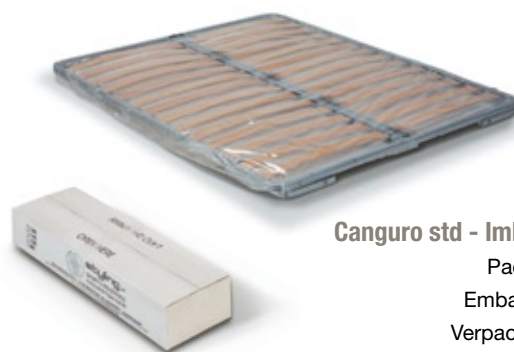
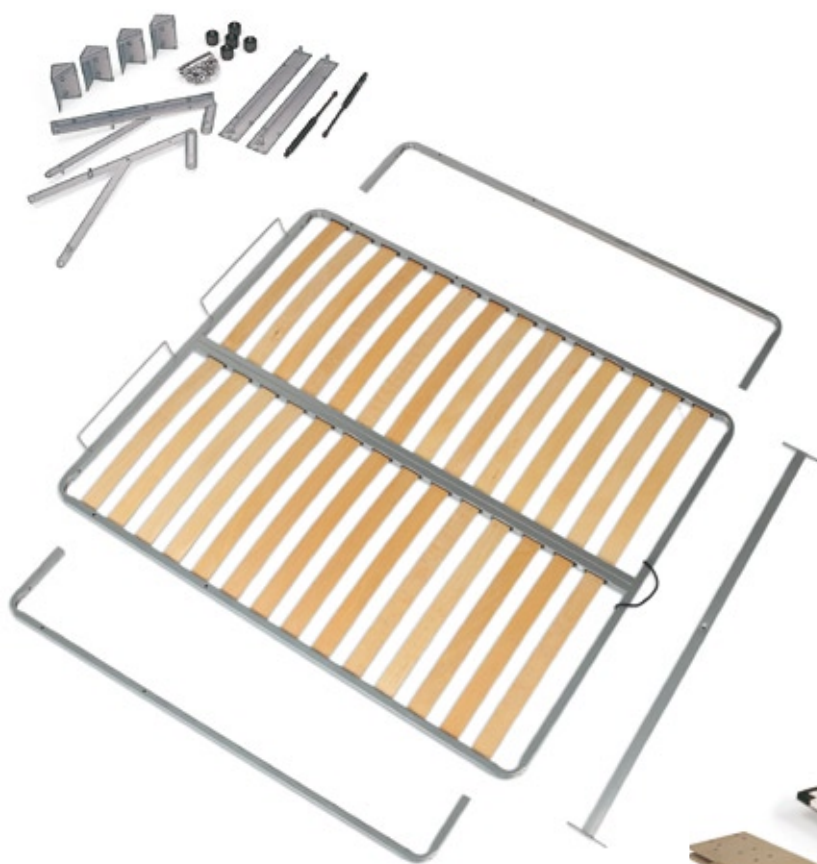

Canguro std - Imballo

Packing
Emballage
Verpackung
Embalaje

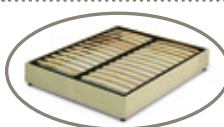

Canguro con cassone - Imballo

Packing
Emballage
Verpackung
Embalaje



Canguro con telaio in ferro

Imballo
Packing
Emballage
Verpackung
Embalaje

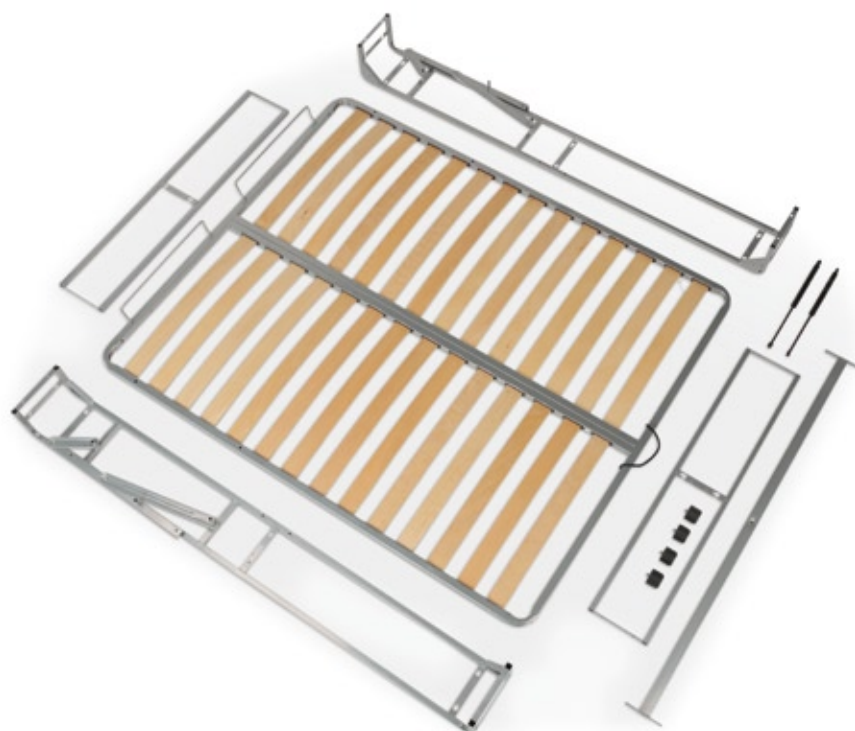



CASSONE | Aperto • Open • Ouvert • Offen • Abierto

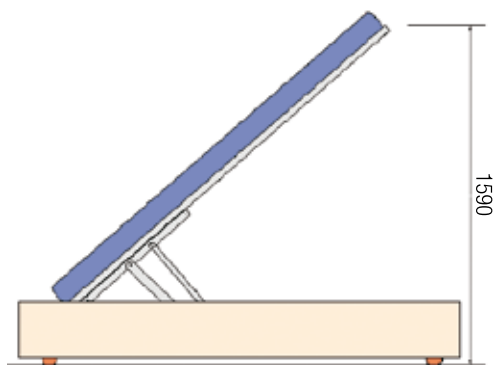

CON TELAIO | Aperto • Open • Ouvert • Offen • Abierto

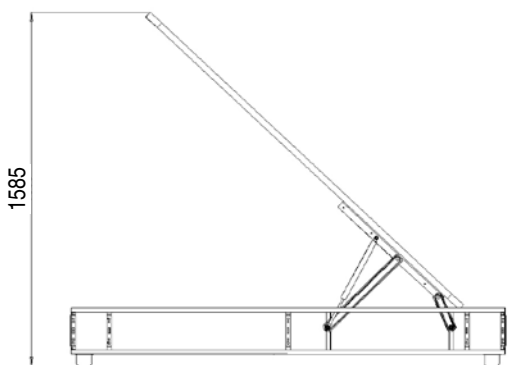

CASSONE | Chiuso • Closed • Fermé • Geschlossen • Cerrado

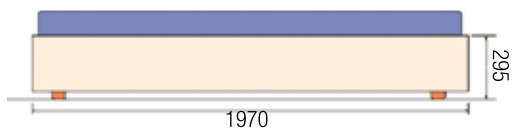

CON TELAIO | Chiuso • Closed • Fermé • Geschlossen • Cerrado

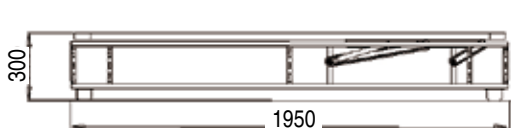

CASSONE | Materasso • Mattress • Matelas • Matratze • Colchón

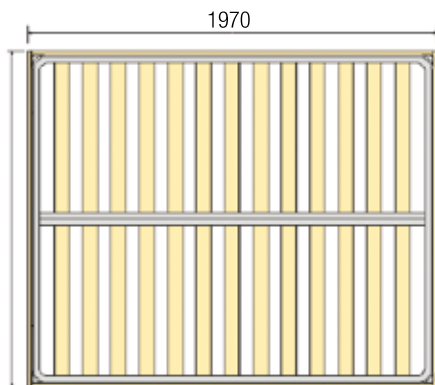

CON TELAIO | Materasso • Mattress • Matelas • Matratze • Colchón

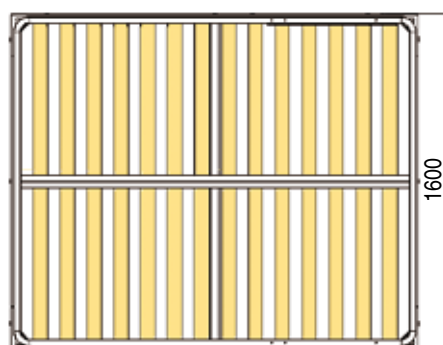

mm.
800
1200
1400
1600
C

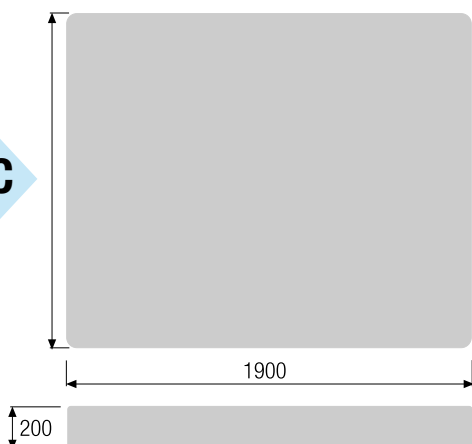

mm.
800
1200
1400
1600
C

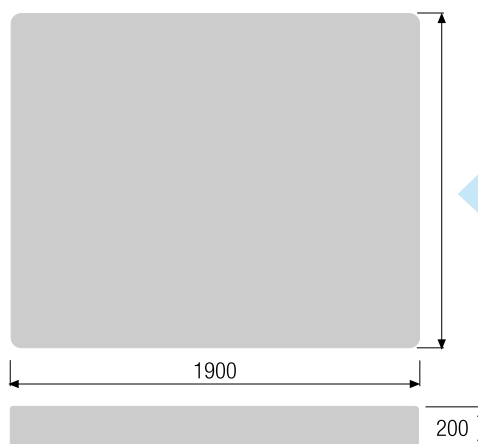

english

Thanks to a set of kinematic mechanisms equipped with gas-powered pumps the front-side sliding system allows the use of the compartment under the spring for cushions and blankets.

The bed base of the model TwoWays can be pulled forward after being uplifted and placed on the floor at a height that make it easier to put the bed back to its original place.

It is realized with highly-resistant cold-rolled steel tubes of top quality and is lacquered with epoxy resins in high temperature oven. The orthopedic bed base is made up of curved wooden slats.

The version with the iron frame that can be completely disassembled is also available.

A simple and rapid assembly allows the sale of the kit.

español

Cama que, al levantar el somier, deja libre un hueco puesto debajo del el, útil para guardar almohadas y mantas: este movimiento está permitido por una pareja de mecanismos cinemáticos de levantamiento dotados de bombas de gas.

La versión TwoWays permite desplazar hacia delante el somier después de levantarlo, para ponerlo a una altura del suelo idónea para una rápida re-sistemación de la cama. Ha sido realizado con tubos de acero rodados en frío de alta resistencia; está barnizado a polvo en horno en alta temperatura.

El somier es ortopédico, hecho por láminas de haya curvas.

Disponible también en la versión con armazón en hierro, aunque este completamente desmontable.

Como es posible montarlo muy sencilla y rápidamente, permite que se venda en kit de montaje.

italiano

Letto contenitore che, mediante sollevamento del piano dormita, rende disponibile un vano collocato sotto la rete, utile per riporre cuscini e coperte: tale movimento è consentito da una coppia di cinematismi di sollevamento dotati di pompe a gas.

La versione TwoWays consente di tirare in avanti il piano dormita, dopo averlo sollevato, per posizionarlo ad un'altezza dal pavimento idonea ad una agevole sistemazione del letto. È realizzato con tubi in acciaio laminati a freddo di qualità ad alta resistenza; è verniciato a polvere in forno ad alta temperatura.

Il piano dormita è ortopedico, in doghe di faggio curve.

Disponibile anche nella versione con telaio in ferro, anch'esso completamente smontabile.

La possibilità di essere montato con estrema facilità e velocità ne consente la vendita in kit.

français

Grâce à un système de soulèvement du plan couchage actionné par un couple cinématique de soulèvement pourvu de pompes à gaz, il est possible d'utiliser un coffre de rangement pour les coussins et les couvertures.

Le modèle TwoWays permet d'avancer le plan de couchage après l'avoir soulevé et de le placer sur le sol à une hauteur indiquée pour un rangement confortable du lit.

Le système est réalisé avec des tubes en acier forgés à froid à haute résistance de bonne qualité. Vernissage à la poudre époxyde noire cuite au four à haute température.

Plan de couchage orthopédique avec lattes courbées en bois. La version avec le châssis en fer complètement démontable est aussi disponible.

Grâce à son assemblage simple et rapide il est possible de vendre le modèle en kit.

deutsch

Bettsofa mit Kasten; beim Anheben der Liegefläche kommt sich unter dem Metallgitterrost ein Kasten zum Vorschein, wo man Kissen und Decken unterbringen kann.

Beim Modell TwoWays wird die Liegefläche angehoben und nach vorne herausgezogen. Dies schafft die ideale Höhe über dem Fußboden, um das Bett anschließend wieder bequem im Sofa zu verstauen.

Diese Bettmechanik wird durch zwei Gaspumpengetriebe betätigt.

Höchst widerstandsfähige Struktur aus kaltgeformten Stahlröhren mit Pulver bei hoher Temperatur ofenlackiert.

Die orthopädische Liegefläche ist mit gebogenen Holzlatten ausgestattet.

Erhältlich auch in der Ausführung mit Eisenrahmen, die ebenso völlig zerlegbar ist.

Dank der einfachen und schnellen Montage kann dieses Bettsofa gut als Kit verkauft werden.



styling

Canguro

TWOWAYS





styling

Canguro

TWOWAYS

Versione con telaio in ferro
Version with the iron frame
Version avec le châssis en fer
Ausführung mit Eisenrahmen
Versión con armazón en hierro



styling

Canguro TwoWays

Kit di montaggio

Assembly kit · Kit d'assemblage · Montagekit · Kit de montage



Canguro TwoWays std Imballo

Packing
Emballage
Verpackung
Embalaje



Canguro TwoWays con cassone Imballo

Packing
Emballage
Verpackung
Embalaje

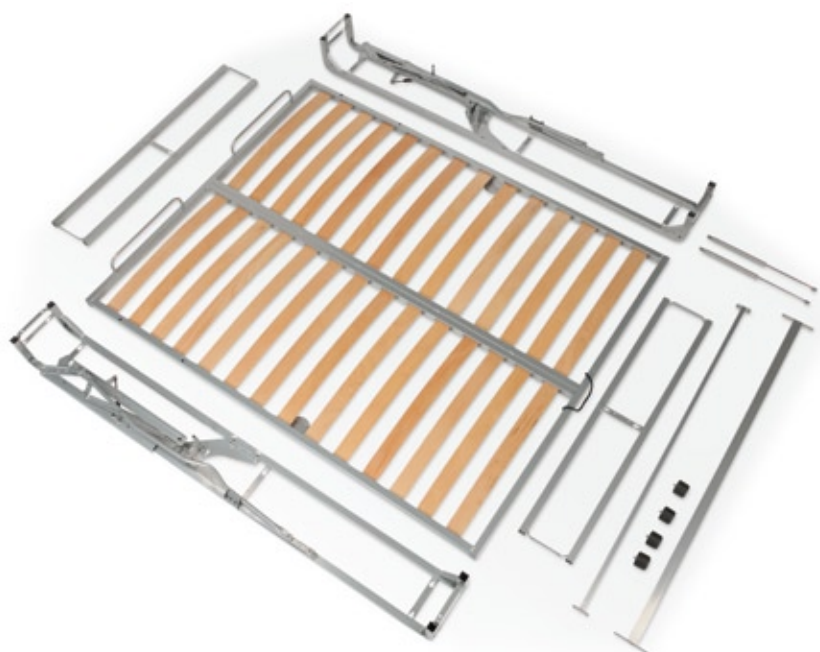

Canguro TwoWays con telaio in ferro - Imballo

Packing
Emballage
Verpackung
Embalaje





CASSONE | Aperto · Open · Ouvert · Offen · Abierto

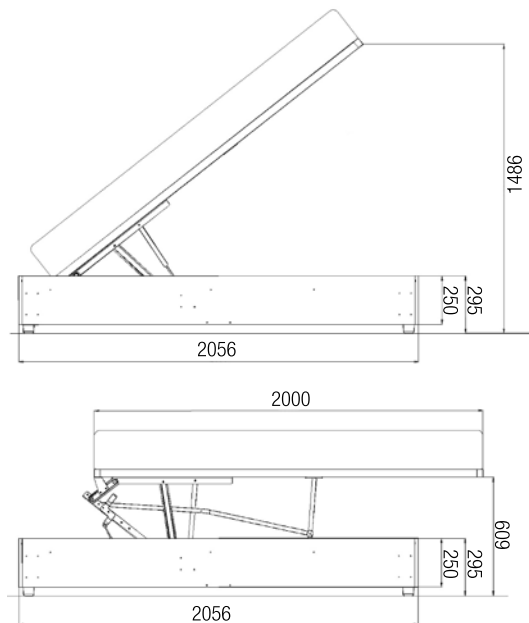

CON TELAIO | Aperto · Open · Ouvert · Offen · Abierto

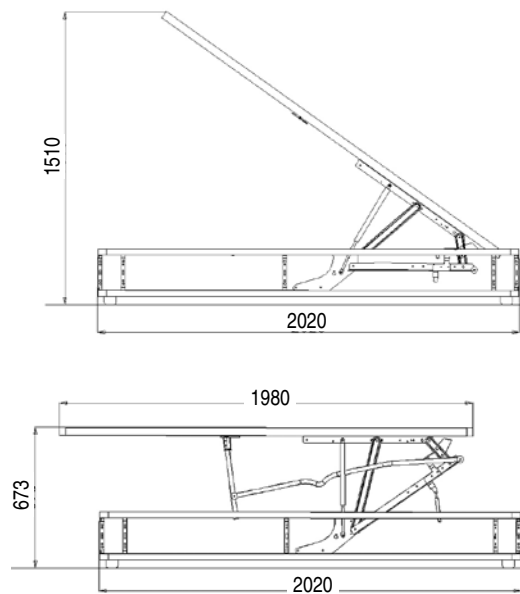

CASSONE | Chiuso · Closed · Fermé · Geschlossen · Cerrado

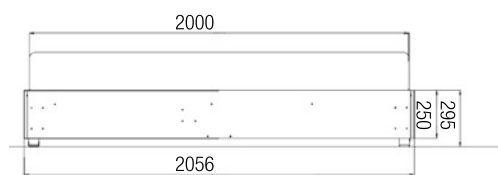

CON TELAIO | Chiuso · Closed · Fermé · Geschlossen · Cerrado



CASSONE | Materasso · Mattress · Matelas · Matratze · Colchón

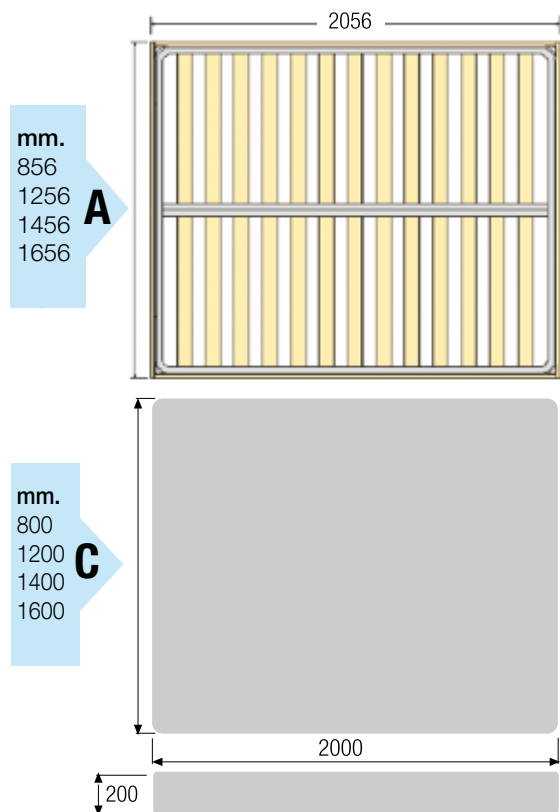

CON TELAIO | Materasso · Mattress · Matelas · Matratze · Colchón

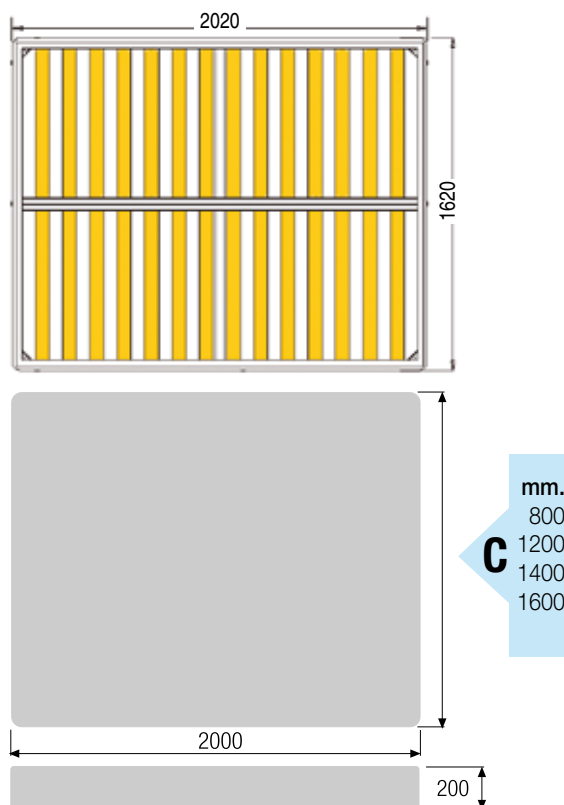

english

Single storage bed provided with a set of kinematic mechanisms equipped with gas-powered pumps that allow to lift the bed base and to open the compartment under the spring for cushions and blankets.

The mechanism is realized with top-quality highly-resistant cold-rolled steel tubes and is lacquered with epoxy resins in high temperature oven.

The orthopaedic bed base is made up of curved wooden slats.

A simple and rapid assembly of both the mechanism and the iron frame allows the sale of the kit.

español

Cama recipiente individual que, mediante el levantamiento lateral del plano somier, deja disponible un vano colocado bajo la red, útil para colocar almohadas y mantas.

Tal movimiento lo consiente una pareja de cinematismos de levantamiento dotados de pompas a gas.

Está realizado con tubos de acero laminados en frío de alta calidad y alta resistencia; y barnizados en polvo en horno a alta temperatura.

El somier es ortopédico, en láminas de Haya curvas.

La posibilidad de montar sea el mecanismo que el armazón de hierro con extrema facilidad y velocidad permite su venta en piezas.

italiano

Letto contenitore singolo che, mediante il sollevamento laterale del piano dormita, rende disponibile un vano collocato sotto la rete, utile per riporre cuscini e coperte.

Tale movimento è consentito da una coppia di cinematismi di sollevamento dotati di pompe a gas.

È realizzato con tubi in acciaio laminati a freddo di qualità ed alta resistenza; è verniciato a polvere in forno ad alta temperatura.

Il piano dormita è ortopedico, in doghe di faggio curve.

La possibilità di montare sia il meccanismo che il telaio in ferro con estrema facilità e velocità ne consente la vendita in kit.

français

Lit-coffre simple pourvu d'un système de soulèvement latéral du plan couchage actionné par des pompes à gaz pour l'ouverture d'un coffre de rangement pour les coussins et les couvertures. Le système est réalisé avec des tubes en acier forgés à froid à haute résistance de bonne qualité.

Le système est vernissé avec poudre époxyde noire cuite au four à haute température. Le plan de couchage orthopédique est pourvu de lattes courbes en bois.

Grâce à l'assemblage simple et rapide aussi bien du mécanisme que du châssis en fer, le modèle peut être vendu en kit.

deutsch

Einzelbettsofa mit Kasten. Beim Seitenanheben der Liegefläche kommt sich unter dem Metallgitterrost ein Kasten zum Vorschein, wo man Kissen und Decken unterbringen kann.

Diese Bettmechanik wird durch zwei Gaspumpengetriebe betätigt.

Höchst widerstandsfähige Struktur aus kaltgeformten Stahlröhren mit Pulver bei hoher Temperatur ofenlackiert.

Die orthopädische Liegefläche ist mit gebogenen Buchenholzplatten ausgestattet.

Dank der einfachen und schnellen Montage vom Mechanismus und vom Eisenrahmen kann dieses Bettsofa gut als Kit verkauft werden.



styling

Canguro

Laterale Singolo



styling

Canguro

Laterale Singolo

Kit di montaggio

Assembly kit · Kit d'assemblage · Montagekit · Kit de montage

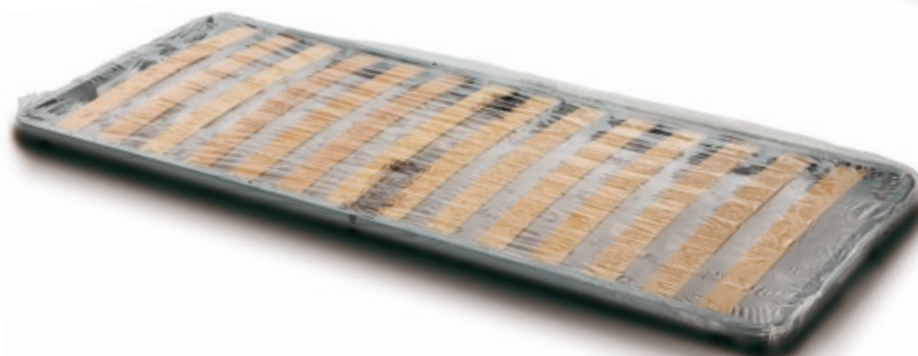
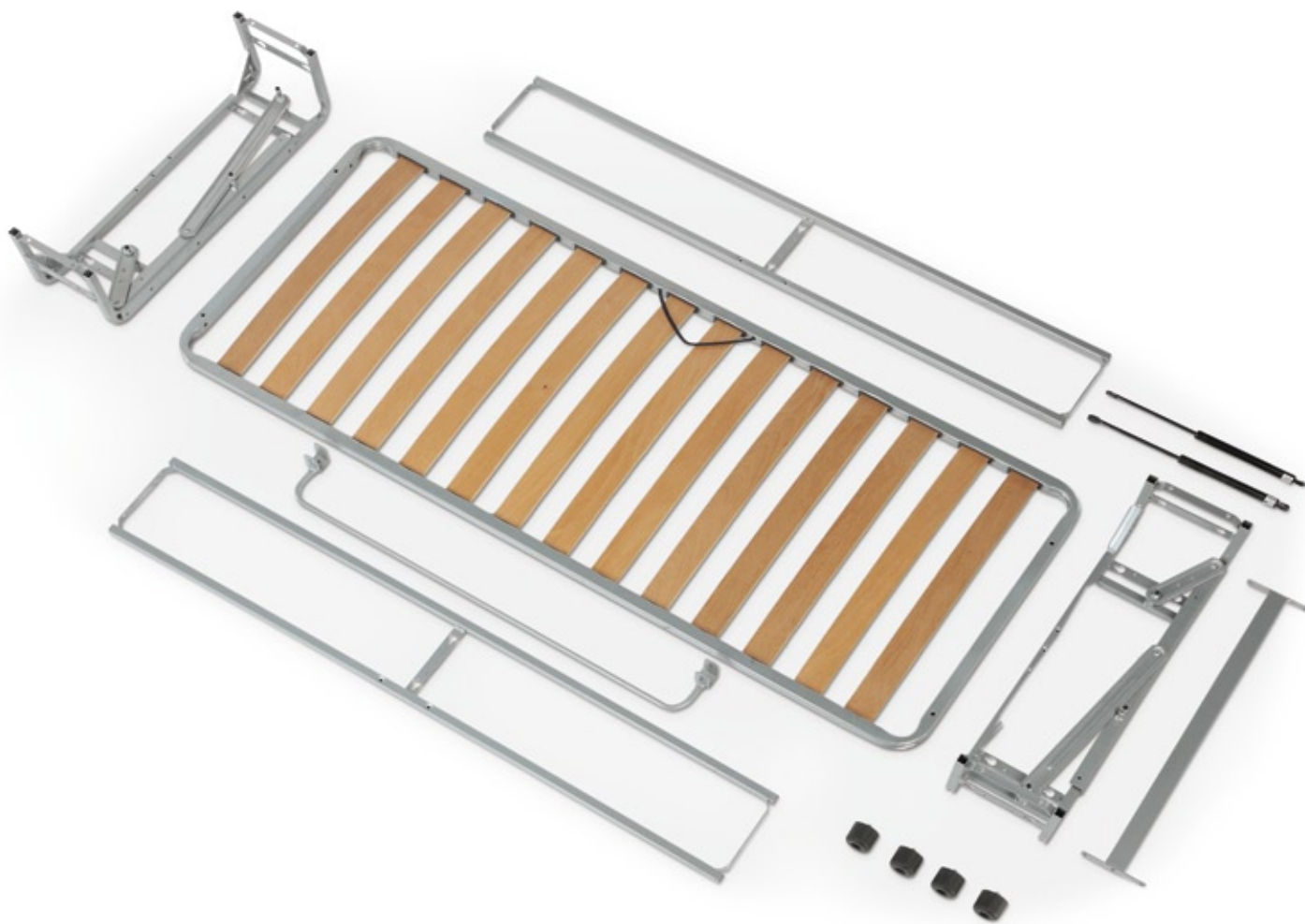



Aperto • Open • Ouvert • Offen • Abierto

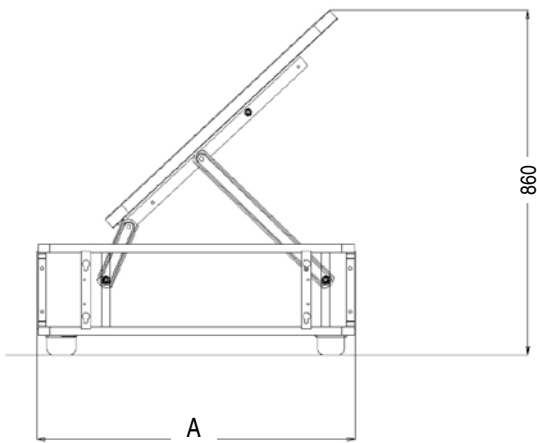

mm.

800

850

900

Chiuso • Closed • Fermé • Geschlossen • Cerrado



Materasso • Mattress • Matelas • Matratze • Colchón

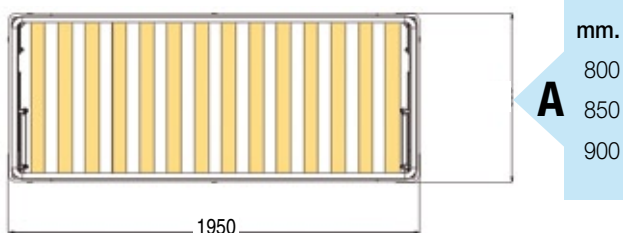

mm.

800

850

900

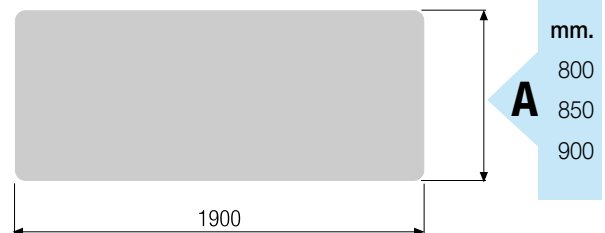

mm.

800

850

900





Factory Design

GLOBAL INTERIER

GLOBAL INTERIER, M.Hökl

Masná 34, 602 00 Brno

Tel. +420 548210647, 8

Fax. +420 548210647, 8

www.globalinterier.com

info@globalinterier.com